

## 5 Internet connection

Hub 2 supports Ethernet or Wi-Fi for its internet connection. For best long-term reliability use Ethernet.

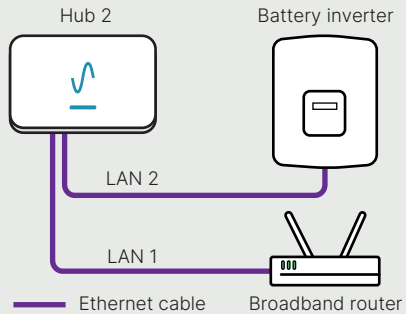

1. Connect an Ethernet cable to the 'LAN 1' port on Hub 2 and a spare network port on the broadband router
2. Optionally, to share a single internet connection through Hub 2, connect an Ethernet cable to the 'LAN 2' port on Hub 2 and the internet port on the battery inverter

### IMPORTANT:

- Avoid routing Ethernet cables alongside 230 V AC cables
- Avoid using powerline adaptors or Wi-Fi extenders

To use Wi-Fi, follow in app instructions during commissioning (see next step).

### IMPORTANT:

- Wi-Fi set up will use Bluetooth to connect to Hub 2. You must be within Bluetooth range for the connection to succeed
- Wi-Fi signal strength at Hub 2 must be sufficient to provide a reliable connection

## 6 Installer commissioning

1. With the installer's phone, scan the QR code on the introduction leaflet or on the side of Hub 2 using the Levelise app
2. Follow instructions in app



## 7 Homeowner registration

1. The homeowner should scan the QR code on the side of Hub 2 or the introduction leaflet
2. Follow instructions in app

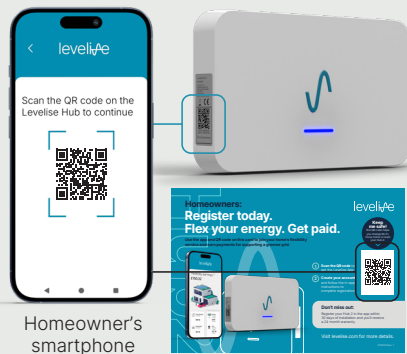

For technical support, including written and video guides, visit [support.levelise.com](https://support.levelise.com)

levelise

# Hub 2

## Quick Installation Guide

### Installation steps

1. Ensure the intended battery system is compatible with Levelise Hub 2
2. Install the battery system according to manufacturer's instructions
3. Install Hub 2 meter on the supply to the battery inverter
4. Mount Hub 2 securely on the wall
5. Connect Hub 2 to the inverter and the Hub 2 meter
6. Power on and connect Hub 2 to the internet
7. Commission Hub 2 (by the installer)
8. Homeowner app registration (by the homeowner)



### Package contents

|  |                            |
|--|----------------------------|
|  | Hub 2                      |
|  | Wall bracket               |
|  | Registration leaflet       |
|  | Fixing kit                 |
|  | Hub 2-Meter RS485 cable    |
|  | Hub 2-Inverter RS485 cable |
|  | 2x RJ11 connectors         |
|  | Power cable                |

### Required

|  |                                    |
|--|------------------------------------|
|  | Pozi #2 screwdriver                |
|  | Drill & 6 mm drill bit             |
|  | Spirit level                       |
|  | Smartphone                         |
|  | RJ45 crimping tool                 |
|  | Cat5 cable                         |
|  | Wire cutters and strippers         |
|  | Eastron SDM230-NMI-2 (Hub 2 Meter) |

## 1 Installation overview

### IMPORTANT:

Hub 2 must be installed by a qualified electrician

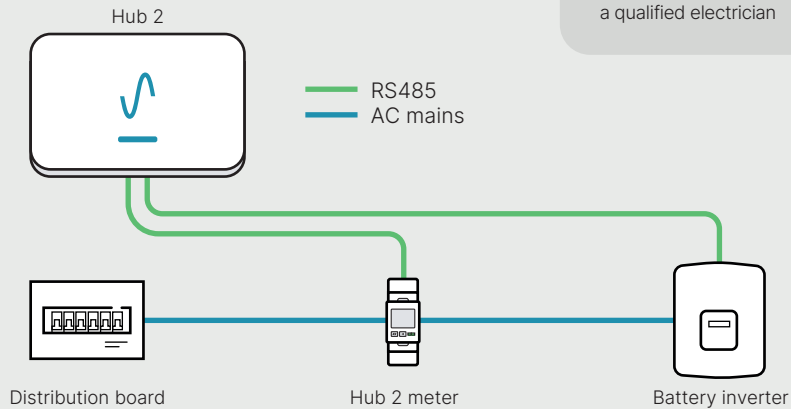

## 2 Mounting

Mount the wall bracket using appropriate fixings. Arrow pointing up.

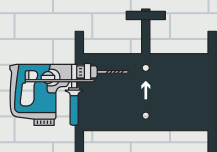

Wall bracket

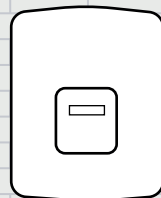

Battery inverter

Clip Hub 2 onto wall bracket.



Hub 2

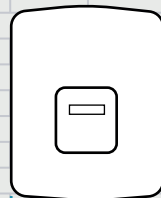

Battery inverter

> 100 mm

## 3 Connect Hub 2 RS485 to battery inverter

### For compatible SolaX products:

1. Plug the 'INVERTER' connector on the supplied inverter RS485 cable into the battery inverter port labelled 'COM/LCD'
2. Plug the 'HUB 2' connector on the supplied inverter RS485 cable into the Hub 2 port labelled 'RS485 1'

### For other compatible inverter brands:

1. Modify the supplied inverter RS485 cable to match the inverter RS485 connection in the table below and connect to the battery inverter's RS485 port:

| BRAND     | CONNECTOR   | BLUE (RS485 A) | BLUE & WHITE (RS485 B) |
|-----------|-------------|----------------|------------------------|
| Afore     | RJ45        | Pin 3          | Pin 6                  |
| Alpha ESS | RJ45        | Pin 5          | Pin 4                  |
| Fox ESS   | Proprietary | Pin 4          | Pin 3                  |
| SolaX     | RJ45        | Pin 4          | Pin 5                  |

2. Plug the 'HUB 2' connector on the supplied inverter RS485 cable into the Hub 2 port labelled 'RS485 1'

For detailed guides visit [support.levelise.com](http://support.levelise.com)

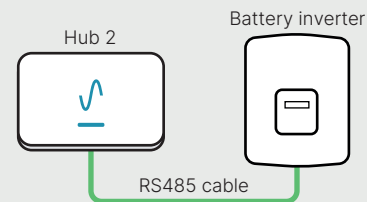

### IMPORTANT:

- Maintain a 50 mm gap between comms and power cables
- Always use two sensors with compatible AC-coupled battery systems – one for grid import/export and one for solar generation
- When using CTs, avoid extending the cables as this will impact their accuracy

## 4 Connect Hub 2 RS485 to meter

From distribution board      To inverter

L-in      L-out

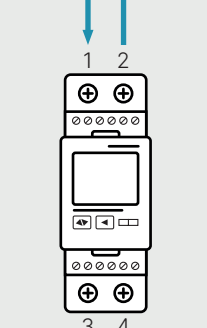

Hub 2 monitors the battery inverter's output using an Eastron SDM230-NMI-2 meter. This must be installed for Hub 2 to properly function.

1. Wire the meter such that terminal 1 connects to the supply from the distribution board and terminal 2 connects to the battery inverter
2. Using the supplied RS485 cable, connect the end labelled 'Meter' to the meter so the orange wire is in terminal 9 and the orange and white wire is in terminal 10
3. Connect the end labelled 'HUB 2' to the port marked 'RS485 2' on Hub 2



|             | GREEN (GROUND) | ORANGE (RS485 B) | ORANGE & WHITE (RS485 A) |
|-------------|----------------|------------------|--------------------------|
| Hub 2 meter | Terminal 8     | Terminal 9       | Terminal 10              |
| Hub 2 RJ11  | Pin 2          | Pin 3            | Pin 4                    |

### IMPORTANT:

- Install meter in suitably rated enclosure
- Ensure meter is set to baud rate 19,200 and address 1